



SP-35X

Signal Powered DC Volt Meter
3 1/2 Digit 0.48" LCD
in a Slim Bezel Case

An easy-to-use DC signal powered volt meter.

General Features

The SP-35X is a signal powered meter designed for ease-of-use. The 2 wire meter is powered from the signal, and does not require a separate power supply. This meter has Auto-Polarity indication. The polarity indication may be disabled or reversed by repositioning jumper clips on internal header pins.

Each SP-Series meter is provided with a set of screw terminal blocks that can accept either bare wire or crimp-on 0.110" x 0.032" insulated disconnects. The SP-Series pin out is designed so that a standard PCB edge connector can also be used instead of the screw terminal blocks if desired.

Typical Application Connections

DC Volts Single-ended measurement with a Resolution of 100 millivolt.

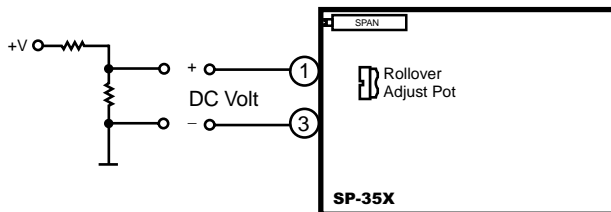

DC Volts Differential measurement with a Resolution of 100 millivolt.

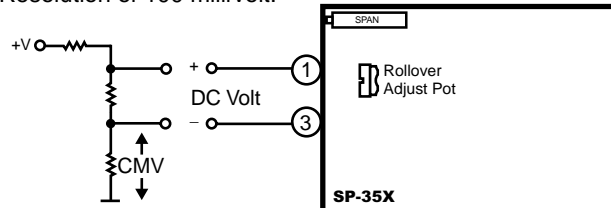

Max CMV (common mode voltage) is 50V.*

*Because CMV is common with meter ground, higher CMV inputs to a max of 1KV, require mechanical isolation of all contactable meter parts.

Compatibility

The SP-Series is shipped in a standard Slim Bezel case. The Slim Bezel case is compatible with the CM, SM, PM, & TM Series of meters. The SP-Series can be ordered in End Mount cases for twin mounting or combinations of multiple center mount cases and two end mount cases for stack mounting.

SLIM



BEZEL

Specifications

Input Configuration:Single-ended

Input Impedance:For inputs above 100V.....50K Ω to 60K Ω
40V to 100VDC inputs 30K Ω to 50K Ω
3.5V to 40V inputs.....10K Ω to 30K Ω

Full Scale Ranges: ± 199.9 V DC. Minimum voltage that can be measured is approx. ± 3.5 V DC.
Recommended minimum input is 5V DC

A/D Converter:12 bit dual slope A/D converter

Accuracy: $\pm (0.05\%$ of reading + 2 digits)

Temperature Coefficient:...100ppm/ $^{\circ}$ C typical

Warm Up Time:10 seconds to specified accuracy

Conversion Rate:3 readings per second

Display:.....0.48" Liquid Crystal Display (LCD)

Decimal Selection:.....None Fixed at 1XX.X

Positive Overrange:.....1 (MSD) is displayed with all other digits blank.

Negative Overrange:1 (MSD) and - sign are displayed with all other digits blank.

Power Supply:.....No power supply needed. Powered from the input signal

Operating Temperature: ... 0° C to $+60^{\circ}$ C

Storage Temperature:..... -20° C to $+70^{\circ}$ C

Relative Humidity:95% (non condensing)

Case Dimensions:.....Bezel 2.76" x 1.17" (69.75 x 29.7mm)
Depth behind Bezel 3.32"(84mm)
plus 0.68" (17.27mm) for connector

Weight:.....143 gms (5 Oz) when packed

SP-Series, low cost meters signal power for polarity indication

SP-35X.....3.5 digit LCD, Signal Powered by DC voltage
SP-35XMV.....3.5 digit LCD DCMV Input, 10-100VDC or 18-36VAC Pwr

SP-35XRMS3.5 digit LCD, VAC RMS Signal Pwr, 15.0-199.9VAC/DC

Functional Diagram

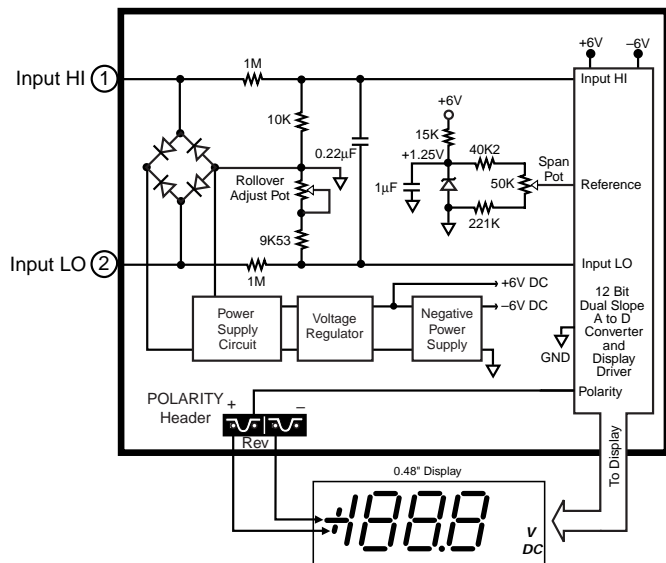

Connector Pinouts

The SP-35X interconnects by means of TB-1 screw terminal clips, which are provided at no cost with the meter. A PCB edge connector (CN-L10) with 0.156" pitch and dual 10 pin rows may also be used. Texmate's proprietary PUSH-ON Connector may also be used. Connector options are shown on page 3.

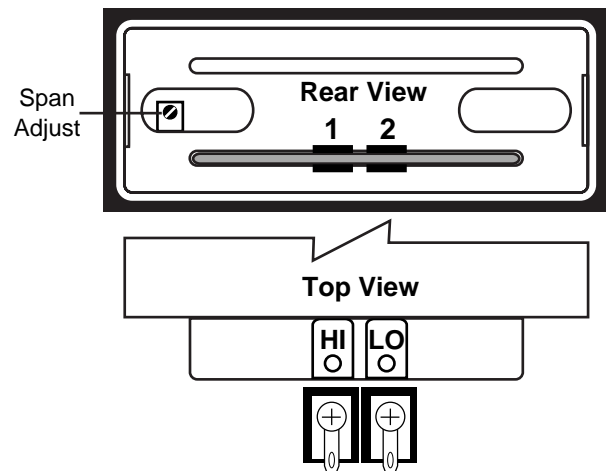

Pin 1 - Input Hi: This is the signal high input to the meter. Voltages from $\pm 3.5\text{V}$ to 199.9V DC may be measured.

Pin 2 - Input Lo: This is the signal low input to the meter. Voltages from $\pm 3.5\text{V}$ to 199.9V DC may be measured.



WARNING: AC and DC input signals and power supply voltages can be hazardous. Do Not connect live wires to screw terminal plugs, and do not insert, remove or handle screw terminal plugs with live wires connected.

Component Layout

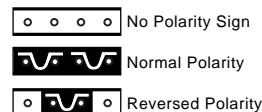
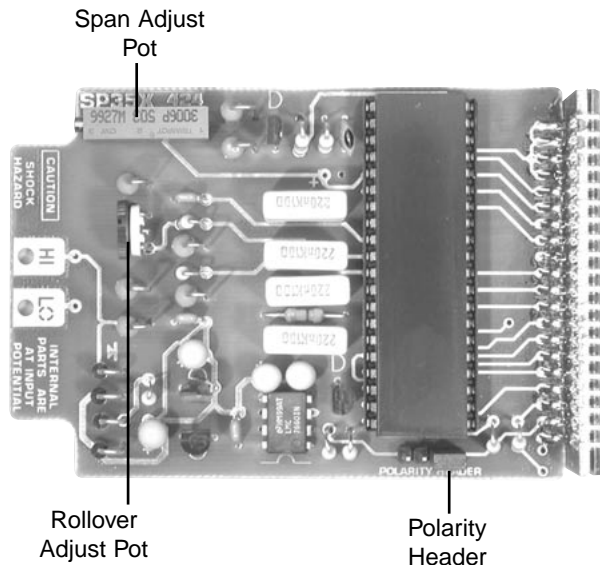

Signal Conditioning Components



ROLLOVER Adjust Potentiometer

The single turn Rollover Adjust Pot is accessed by removing the meter from the case. It is adjusted at the factory and usually does not need to be readjusted.

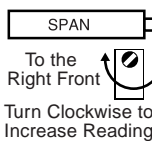

SPAN Potentiometer (Pot)

The 15 turn SPAN pot is always on the left side (as viewed from the back of the meter). Typical adjustment is 20% of the input signal range.

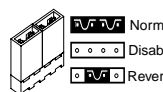

Polarity Display Header

This header allows the Polarity indication to be displayed normally, displayed reversed or to be disabled completely.

Calibration Procedure

- 1) Apply a known DC volt to the meter. Typically, the calibration voltage used is +190V DC.
- 2) Adjust the span pot so that the meter displays the correct reading (+190.0 in this example).
- 3) Reverse the input connections to the meter so that a negative input is being applied (-190V DC in this example).
- 4) Adjust the Rollover Pot so that the meter reads correctly (-190.0 in this example).
- 5) The meter is now calibrated and ready for use.

Measuring Volts and Amps in a DC Powered System

The SP-35X, when used with its companion meter SP-35XMV, is an elegant solution to the problem of measuring and displaying voltage and current in DC powered systems. To simplify the installation when used together, specify the stackable case option to mount both meters in a single cutout. Our customers have used this combination of meters in DC power supplies, DC generators and in battery back-up systems.

Features such as the low current consumption, wide supply range, large 0.8" display, built in V DC and A DC descriptors, simple connections and user friendly re-scaling to match shunts from 50 mV to 100 mV have made the SP-35X and SP-35XMV the choice of OEMs worldwide.

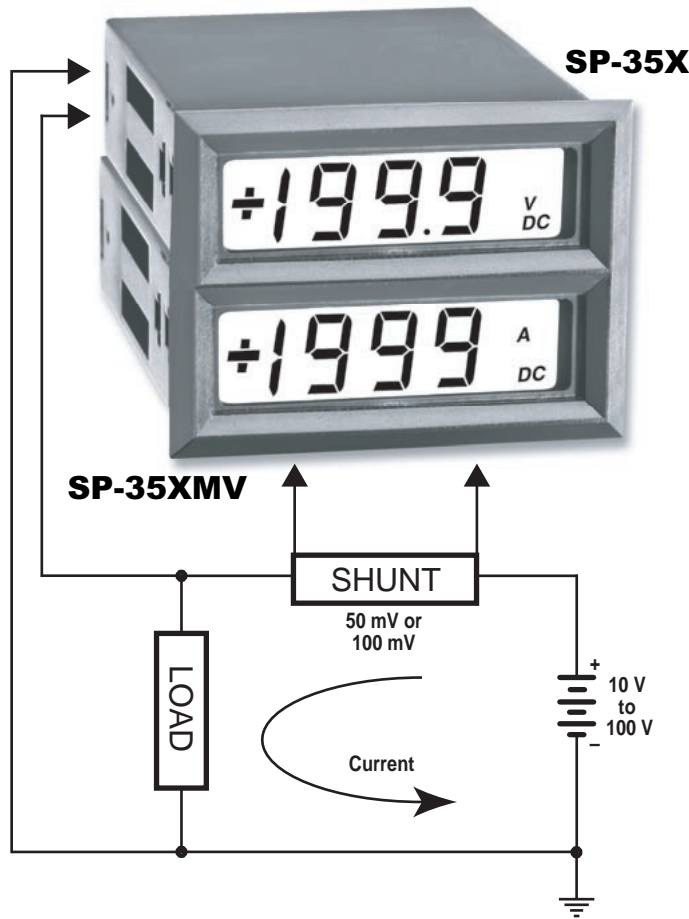

TB-Kit Screw Connectors

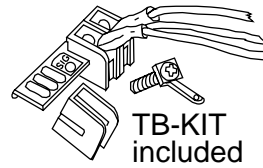

Texmate's individual screw terminal blocks offer a convenient alternative to edge connectors for many applications, allowing complete installation, configuration and calibration without the need for soldering.

Slide each terminal block over the PCB until the hole aligns. Insert the retaining screw to secure. Each kit includes: 3 plastic blocks with metal contacts, 4 screws with spade connectors, 1 metal contact and 3 quick disconnects.

Push-On Screw Terminals

They provide the greatest convenience and ease of use. Texmate's exclusive optional Push-On Connectors combine an edge card connector and a 10 position screw terminal block. Push-On Connectors are ordered preconfigured for each specific power supply voltage and each optional power supply available for the SP-Series.



Part Number: CN-PUSH/SP

Optional PCB Edge Connector

PCB Edge Connector

A standard 20-pin edge connector (two rows of 10 pins on 0.156" centers) may also be used to connect the SP-35X meter. Order part no. CN-L10.

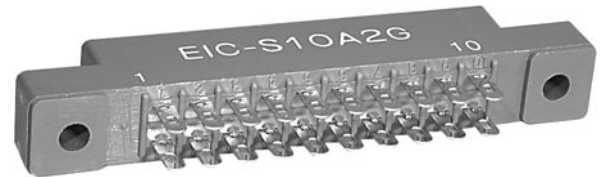

Stack Option



The SP-35X measures DC voltage up to 199.9V. A companion meter, the SP-35XMV measures DC current. The two meters combined in stacking cases are ideal for voltage and current measurements in battery powered systems.

SP Case Dimensions and Panel Cutouts

The Slim Bezel Case is supplied as standard. If specified at time of ordering, any combination of Twin Mounting and Multiple Array Cases may be substituted at no additional cost. Extra cases may be ordered separately.

STANDARD SLIM BEZEL CASE

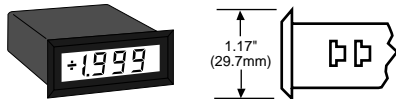

SLIM BEZEL CASE
Standard Black ABS case with matte finish bezel for single unit mounting.

Part No. **SL-CASERED** for LED's
SL-CASECLR for LCD's

OPTIONAL TWIN MOUNTING OR MULTIPLE ARRAY CASES

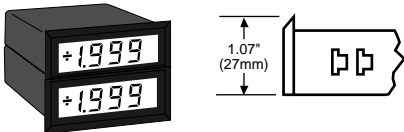

END MOUNT CASE
Same styling as Slim Bezel case but with bottom edge of bezel removed. Two End Mount cases can be twin mounted in a single cutout.

Part No. **EM-CASERED** for LED's
EM-CASECLR for LCD's

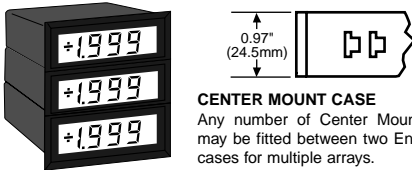

CENTER MOUNT CASE
Any number of Center Mount cases may be fitted between two End Mount cases for multiple arrays.

Part No. **CM-CASERED** for LED's
CM-CASECLR for LCD's

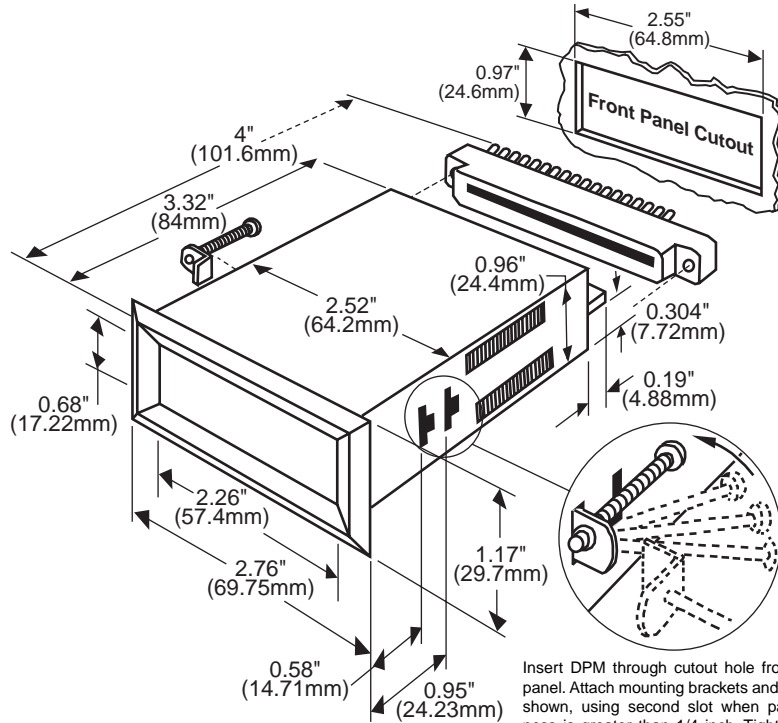

Insert DPM through cutout hole from front of panel. Attach mounting brackets and screws as shown, using second slot when panel thickness is greater than 1/4 inch. Tighten screws against rear of panel.

Ordering Information

Standard Options for this Model Number

Part Number	Description
► BASIC MODEL NUMBER	
SP-35X3.5 digit LCD, Signal Powered by DC voltage

Special Options and Accessories

Part Number	Description
► SPECIAL OPTIONS (Specify Inputs & Req. Reading)	
CB-FS35Non-Std Scale Changes, 3.5 Digit Meters

► ACCESSORIES

- CN-L10Edge Connector with Solder eyelet, 10 Pin Dual
- CN-PUSH/SP . . .Push-on Screw Terminal Block Conn
- TB-KITReplacement Terminal Block Connector Kit (3)
- SL.CASECLR . . .Slim Bezel Case LCD Std case w/mtg hardware
- CM.CASECLR . . .Slim Bezel Center Case LCD w/mtg hardware
- EM.CASECLR . . .Slim Bezel End Case LCD w/mtg hardware

Prices subject to change without notice.

WARRANTY

Texmate warrants that its products are free from defects in material and workmanship under normal use and service for a period of one year from date of shipment. Texmate's obligations under this warranty are limited to replacement or repair, at its option, at its factory, of any of the products which shall, within the applicable period after shipment, be returned to Texmate's facility, transportation charges pre-paid, and which are, after examination, disclosed to the satisfaction of Texmate to be thus defective. The warranty shall not apply to any equipment which shall have been repaired or altered, except by Texmate, or which shall have been subjected to misuse, negligence, or accident. In no case shall Texmate's liability exceed the original purchase price. The aforementioned provisions do not extend the original warranty period of any product which has been either repaired or replaced by Texmate.

USER'S RESPONSIBILITY

We are pleased to offer suggestions on the use of our various products either by way of printed matter or through direct contact with our sales/application engineering staff. However, since we have no control over the use of our products once they are shipped, **NO WARRANTY WHETHER OF MERCHANTABILITY, FITNESS FOR PURPOSE, OR OTHERWISE** is made beyond the repair, replacement, or refund of purchase price at the sole discretion of Texmate. Users shall determine the suitability of the product for the intended application before using, and the users assume all risk and liability whatsoever in connection therewith, regardless of any of our suggestions or statements as to application or construction. In no event shall Texmate's liability, in law or otherwise, be in excess of the purchase price of the product.

Texmate cannot assume responsibility for any circuitry described. No circuit patent or software licenses are implied. Texmate reserves the right to change circuitry, operating software, specifications, and prices without notice at any time.



Local Distributor Address

MetersUSA
www.metersUSA.com
Meters@MetersUSA.com 1 224 365-5935