

BN-45I

24VDC Panel Meter
4 1/2 Digit 0.56" LED
in a 1/16 DIN Case

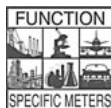

BN-Series



Isolated 24VDC Powered LED Voltmeter in DIN 96x24mm Case.

General Features

The BN-45I is a 4 1/2 digit voltmeter in a compact 96x24mm case with isolated 24VDC power. Another version of the BN-45I, model BN-45, is also available with a non-isolated 5VDC power. The case has a short depth of just 2.83 inches (72mm) behind the panel.

The meter has three user-selectable ranges of 2V, 20V and 200V. The BN-45I may also be calibrated at the factory for these ranges or specially scaled for other ranges (see Ordering Information below). Provision to offset the zero is also available as an option for 4-20mA signals.

The display is shipped standard with red LEDs, but green LEDs or super bright LEDs for high ambient light environments are also offered. Display Segments Test, Display Blank and Hold Reading are standard features.

Typical Application Connections

DC Volts Single-ended

Measurement with a Resolution of 2V.

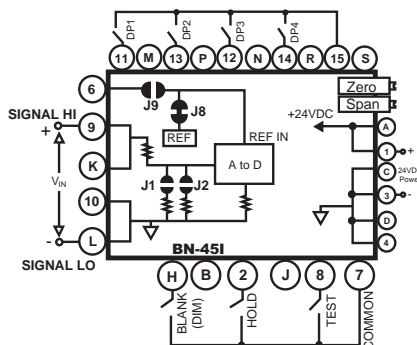

Ratiometric Voltmeter with External Reference

To use the BN-45I as a ratiometric voltmeter with an external reference, open J8 and close J9 jumpers. Connect as shown in the diagram.

NOTE: Signal Low is common to the 24VDC Power Ground.

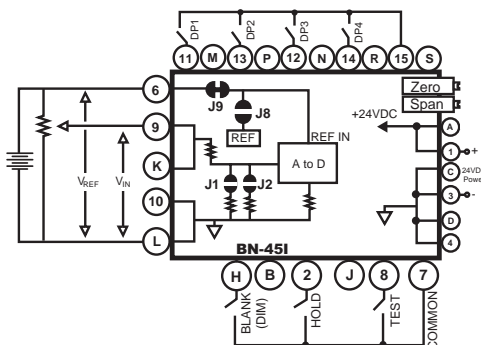

Compatibility

The BN-Series have a matching DIN case style that is complementary to the Lynx, Leopard and Tiger family of meters. BN-Meters are the OEM's choice for economical switchboard and process indication. For economy, each model is dedicated to a specific application and designed for quick and easy installation.

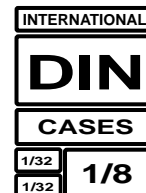

Specifications

Input Configuration:Single ended with provision to offset zero

Full Scale Ranges:±1.9999VDC (standard) ±19.999VDC
±199.99VDC

Input Impedance:Approx. 1MΩ

Input Protection:±250VAC/DC for all range

Conversion Rate:3 readings per second

Accuracy:± (0.05% of reading + 3 digits)

Temp. Coefficient:10ppm/°C in ratiometric mode 50ppm/°C in 2V ranges

Maximum Resolution:100μV in 2V range.

Zero Stability:.....Autozeroed. 0.1 counts per °C

Display:.....0.56" high red LEDs. Display Hold, Blank and Test provided.

Overrange Indication:All digits flash to indicate overrange

Power Supply:.....24VDC at 100mA (standard) internally isolated Optional 12V or 15V isolated supply

Operating Temperature: ..0°C to 60°C

Storage Temperature:.....-40°C to 85°C

Relative Humidity:95% (non condensing)

Case Dimensions:Bezel: 96X24 mm (3.62" X 0.95")
Depth behind bezel: 56.5 mm (2.23")
Plus 27 mm (1.06") for Push-On connector or plus 17.5 mm (0.68") for Edge connector

Weight:.....85 gms (3 oz)
125 gms (4.4 oz) when packed

BN-Series, For Those Applications Where Space Is A Premium

BN-350.2/2/20/200V DC ranges, 3.5 digit, 5V DC Powered
BN-35BCDParallel or Multiplex BCD, 3.5 digit, 5V DC Powered
BN-35CL4 to 20mA, Isolated 24V DC, 3.5 digit
BN-35I0.2/2/20/200V DC ranges, Isolated 24V DC, 3.5 digit

BN-40BCDParallel or Multiplex BCD, 4.0 digit, 5V DC Powered
BN-452/20/200V DC ranges, 4.5 digit, 5V DC Powered
BN-45I2/20/200V DC ranges, Isolated 24V DC, 4.5 digit

Functional Diagram

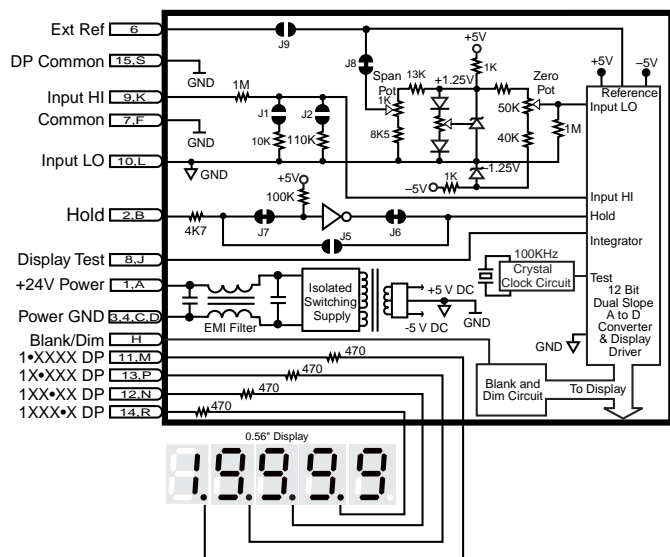

Connector Pinouts

The Texmate model BN-451 interconnects by means of a standard PC board edge connector having two rows of 15 pins, spaced on 0.156" centers. Texmate also offers a Push-On screw terminal connector that provides a great advantage in ease-of-use (see pg. four). Connectors are available from Texmate.

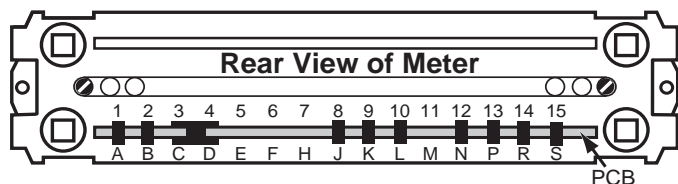

METER REAR WITH PCB EDGE CONNECTOR MOUNTED

(For mounting of screw terminal blocks see rear page)

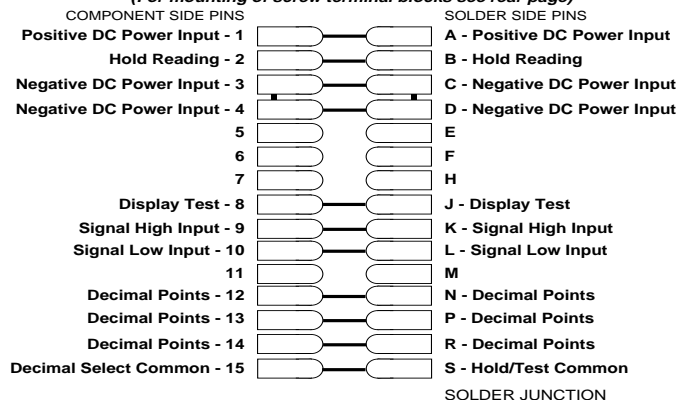

Pins 1 & A - Positive DC Power Input: These pins are internally connected together. The positive end of the DC power is connected to these pins. The standard BN-451 meter is designed to be powered from an isolated 24VDC power supply. Other power supplies options are available. See page three. Before using the meter, make sure that the appropriate power is being applied.

Pins 2 & B - Hold Reading: These pins are internally connected together. If these pins are left unconnected, the meter will operate in a free-running mode. When these pins are connected to the Hold/Test/Blank Common Pin 7, the meter will latch up. A/D conversions will continue, but the display will not be updated until Pins 2 & B are disconnected from Pin 7.

Pins 3, 4, C, and D - Negative DC Power Input: These pins are

internally connected together. The negative end of the DC power is connected to these pins. The standard BN-451 is designed to be powered from a 24VDC supply. Other power supply options are also available. See page three.

Pin 6 - External Reference Input: See page three for operating the meter with an external reference as a ratiometric volt-meter.

Pin 7 - Hold/Test/Blank Common Pin: The Display Hold/Test/Blank pins have to be connected to this pin to be activated.

Pin H - Display Blank: If this pin is connected to Pin 7, the display will be blanked out.

Pins 8 and J - Display Test: These pins are internally connected together. All numeric display segments will light up when these pins are connected to the Hold/Test Blank Common Pin 7.

Pins 9 and K - Signal High Input: These pins are internally connected together. Signal high input for the meter. The input voltage can range from 2V to 200VDC. By closing some solder jumpers, the user can change from one range to another. See page three for range change information.

Pins 10 and L - Signal Low Input: These pins are internally connected together to the power ground Pin 3. Signal low input of the A/D Converter.

Pins 11 & M, 12 & N, 13 & P and 14 & R - Decimal Points: These are the decimal point pins. Connecting any of these pins to the Decimal Select Common Pin makes that particular decimal point come on.

Pins 15 and S - Decimal Select Common: These pins are internally connected together. The decimal point pins must be connected to this pin to come on.

Component Layout

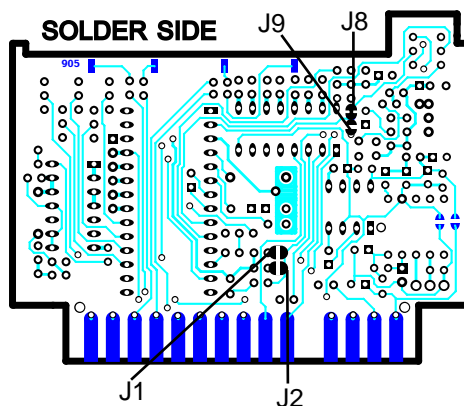
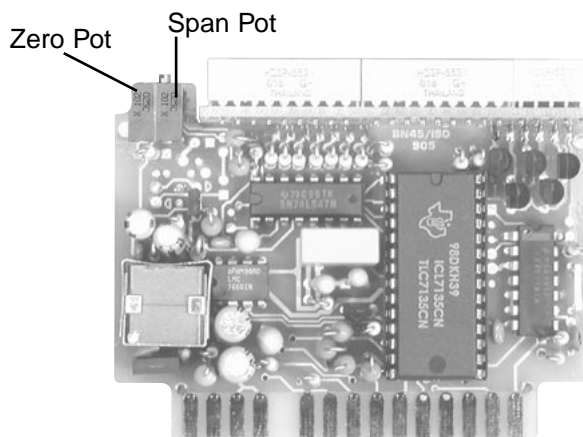

Signal Conditioning Component

ZERO

ZERO Potentiometer (Pot)

To the Left Front
Turn Clockwise to Increase Reading



The Optional ZERO pot when installed is always to the left of the SPAN pot (as viewed from the front of the meter). Typically it enables the displayed reading to be offset ± 1000 counts.

SPAN

SPAN Potentiometer (Pot)

To the Right Front
Turn Clockwise to Increase Reading



The 15 turn SPAN pot is always on the right side (as viewed from the front of the meter). Typical adjustment is 20% of the input signal range.

Calibration Procedure

The BN-45I is calibrated at the factory with a precision DC voltage source. Whenever the range is changed, the meter needs to be recalibrated. The Span Potentiometer is accessible with the front cover of the meter removed for user calibration.

1. Make sure there is proper DC power and input.
2. Connect the power supply.
3. Apply a positive signal input equal to 95% of the full scale input.
4. Adjust Span Potentiometer in the front of the meter so that the displayed reading agrees with the signal input.
5. The BN-45I is now calibrated and ready for use.

Input Range Selection

Changing the range to 20V or 200V full scale. The BN-45 comes standard as a 2VDC meter. The factory can recalibrate the meter to a different range either when the meter is ordered or as an after sale service using part number VRC-DPM.

For the user to change the range, closing of some jumpers by soldering and opening other jumpers is required. Follow the chart below to achieve the required range. See the above component layout to find location of jumpers. Remember to recalibrate the meter after every range change.

Desired Range	Open Jumper	Closed Jumper
2V	J1 and J2	—
20V	J2	J1
200V	J1	J2

Opening Back Panel

Unscrew the knurled collars, and remove the mounting clips. Snap out the rear plastic plate. The BN-45I printed circuit board can then be easily removed by sliding it out from the rear of the case.

Front Bezel Descriptors

AC	Ω	kV	kVAR	m^3/hr	Hz	RPM
V	mV	min	PF	$^{\circ}F$	$^{\circ}C$	Cos ϕ
DC	$\times 10kN$	μA	PSIG	mS	kg/cm^2	psi
KW	W	KWH	pH	%	K	kPa
A	mbar	mA	MW	kA	RPS	MWH
mWs	μm	kW/s	I	I/sec	ml	cm
ORP	mm/s	1/min	mm	kg/sec	lbs	kg/hr
FT	bars	min 1	m/min	Mvars	μV	dB

To customize the front bezel, each DU-meter is supplied with a white printed clear adhesive label containing various popular descriptors. Choose the descriptor desired, peel off the adhesive backing and align the descriptor in the center right of the faceplate.

Power Supply

The BN-45I ships from the factory with 12V, 15V, and 24V power options and generates an internally isolated supply. For applications where isolation isn't required between the power and signal grounds, use the Texmate model BN-45, which is shipped with a non-isolated 5VDC power supply.

Push-On Screw Terminals

They provide the greatest convenience and ease of use

Texmate's exclusive optional Push-On Connectors combine an edge card connector and a 10 position screw terminal block. Push-On Connectors are ordered preconfigured for each specific power supply voltage and each optional power supply available for the BN-Series.

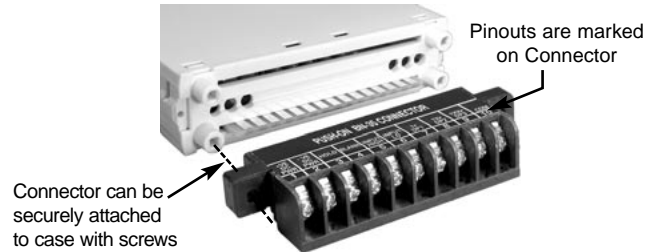

Part Number: CN-PUSH/BN

Optional PCB Edge Connector

PCB Edge Connector

A standard 30-pin edge connector (two rows of 15 pins on 0.156" centers) may be used to connect the BN-45 meter. Order part no. CN-L15.



Custom Face Plates



Texmate Produces Thousands of Custom OEM Face Plates

Have Texmate Design and Build a Custom Face Plate to Suit your Next project!

- Custom face plates have a non-recurring artwork charge. A serial number is then assigned to each artwork, to facilitate re-ordering.
- Small Run or One-Off custom face plates incur an installation charge, and are generally printed on a special plastic film, which is then laminated to custom faceplate blanks as required.
- Large Run (250 pieces min): custom face plates are production silk screened, issued a part number, and held in stock for free installation as required by customer orders.
- OEMs may also order Custom Meter Labels, Box Labels Custom Data Sheets and Instruction Manuals.

BN Case Dimensions and Panel Cutouts

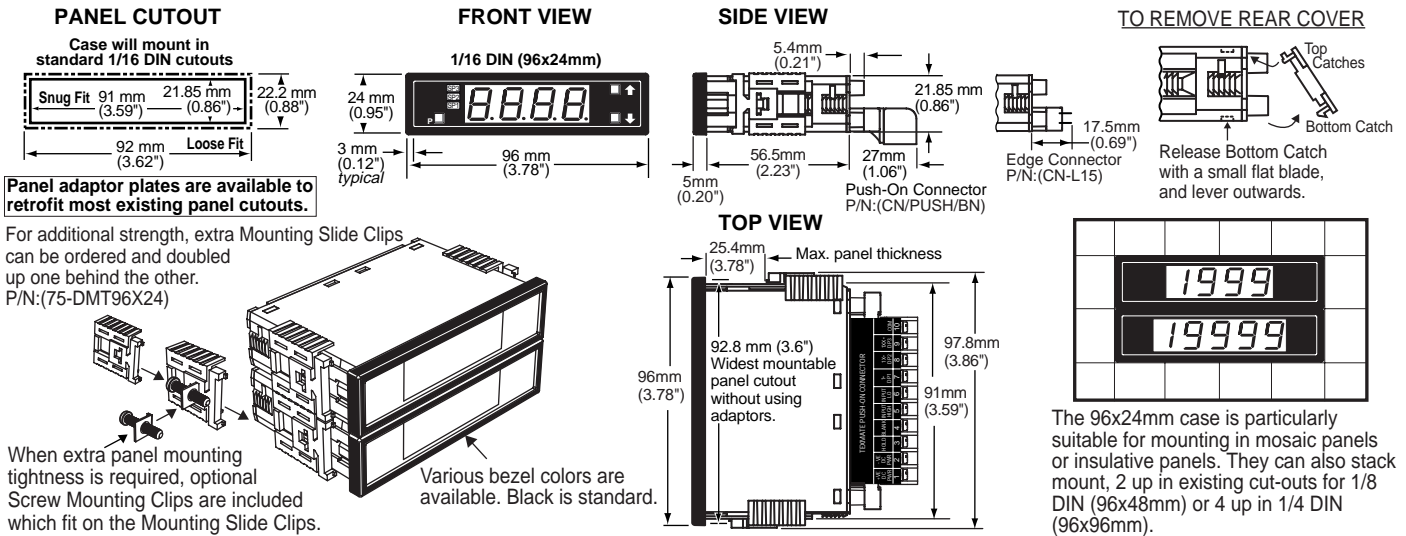

Ordering Information

Standard Options for this Model Number

Part Number	Description	List
► BASIC MODEL NUMBER Includes standard display and standard power supply unless optional versions are ordered.		
BN-451	.2/20/200V DC ranges, Isolated 24V DC, 4.5 digit	\$149
► DISPLAY		
STANDARD	Red LEDs, 0.56 inch high	.N/C
BN-GREEN	Green LED, 0.56 inch high	\$10
BN-BRIGHT	Super bright Red LEDs, 0.56 inch high	\$20
► POWER SUPPLY		
STANDARD	Isolated 24V DC	.N/C
V0-ISO/PS-09	Isolated 9V DC	\$5
V0-ISO/PS-12	Isolated 12V DC	\$5
V0-ISO/PS-15	Isolated 15V DC	\$5
► SPECIAL OPTIONS (Specify Inputs or Outputs & Req. Reading)		
HD-CHANGE	Range change from the standard input as shown in BOLD type	\$7
V0-50K	Zero offset potentiometer 50k	\$5
VRC-DPM	Range change for BN-35/BN-35I listed ranges	\$10

VRC-4/20	Range change for BN-45I, 4 to 20mA	\$10
CB-FS35	Non-Std Range and Scale Changes, 3.5 Digit Meters	\$10
CB-FS45	Non-Std Range and Scale Changes, 4.5 Digit Meters	\$10

Special Options and Accessories

Part Number	Description	List
► ACCESSORIES (Specify Serial # for Custom Artwork Installation)		
CN-L15	PCB Edge Connector, Solder Type, Dual Row 15 Pins	\$3.75
CN-PUSH/BN	BN Series Push-on Screw Terminal Block Connector	\$18
75-DMTC96X24	Side Slide Brackets, extra set (96x24mm only)	\$2
75-DBBZ96X24	Black Bezel for 96x24mm Case, BN and AM series	\$2
DN.CAS96X24	Din Case 96 X 24 Short Depth with Bezel	\$15

Many other options and accessories are available. See full price list for more details.
Prices subject to change without notice.

WARRANTY

Texmate warrants that its products are free from defects in material and workmanship under normal use and service for a period of one year from date of shipment. Texmate's obligations under this warranty are limited to replacement or repair, at its option, at its factory, of any of the products which shall, within the applicable period after shipment, be returned to Texmate's facility, transportation charges pre-paid, and which are, after examination, disclosed to the satisfaction of Texmate to be thus defective. The warranty shall not apply to any equipment which shall have been repaired or altered, except by Texmate, or which shall have been subjected to misuse, negligence, or accident. In no case shall Texmate's liability exceed the original purchase price. The aforementioned provisions do not extend the original warranty period of any product which has been either repaired or replaced by Texmate.

USER'S RESPONSIBILITY

We are pleased to offer suggestions on the use of our various products either by way of printed matter or through direct contact with our sales/application engineering staff. However, since we have no control over the use of our products once they are shipped, NO WARRANTY WHETHER OF MERCHANTABILITY, FITNESS FOR PURPOSE, OR OTHERWISE is made beyond the repair, replacement, or refund of purchase price at the sole discretion of Texmate. Users shall determine the suitability of the product for the intended application before using, and the users assume all risk and liability whatsoever in connection therewith, regardless of any of our suggestions or statements as to application or construction. In no event shall Texmate's liability, in law or otherwise, be in excess of the purchase price of the product.

Texmate cannot assume responsibility for any circuitry described. No circuit patent or software licenses are implied. Texmate reserves the right to change circuitry, operating software, specifications, and prices without notice at any time.

TEXMATE INC

995 Park Center Drive • Vista, CA 92081-8397

Tel: 1-760-598-9899 • USA 1-800-839-6283 • That's 1-800-TEXMATE

Fax: 1-760-598-9828 • Email: sales@texmate.com • Web: www.texmate.com

Texmate has facilities in Japan, New Zealand, Taiwan, and Thailand. We also have authorized distributors throughout the USA and in 28 other countries.

For product details visit www.texmate.com

Local Distributor Address