

BN-35

5VDC Compact Meter
3 1/2 Digit with 0.56" LED
in a 1/16 DIN Case



5VDC Powered, DC Volts Selectable from 200mV / 2V / 20V.

General Features

The BN-35 is a low cost pin for pin functional replacement for the Newport model 215, with many more features. It is a 3 1/2 digit voltmeter in a compact 96x24mm case with non-isolated 5VDC power. Another version of the BN-35, the BN-35I with internally isolated 9V, 12V, 15V or 24VDC power, is also available. The case has a short depth of just 2.83 inches (72mm) behind the panel.

The meter has four user-selectable ranges of 200mV, 2V, 20V and 200V. The BN-35 may also be calibrated at the factory for these ranges or specially scaled for other ranges (see Ordering Information below). Provision to offset the zero is also available as an option for 4-20mA signals.

Typical Application Connections

DC Volts Single-ended measurement

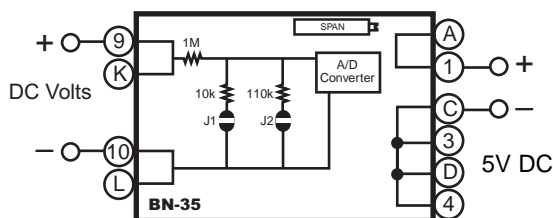

Ratiometric Voltmeter with external reference.

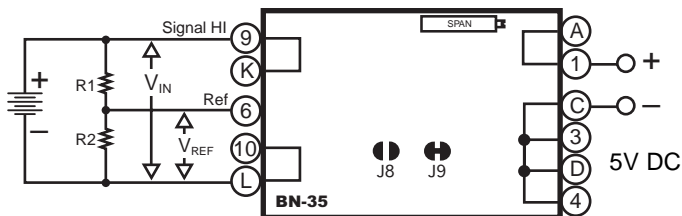

For using the BN-35 as a ratiometric voltmeter with an external reference, open J8 and close J9 jumpers.

$$\text{Meter display} = \frac{V_{IN}}{V_{REF}} \times 1000$$

If Signal Low is common to the 5VDC Power Ground, remove resistor R307 and replace it with a jumper (i.e. short the resistor R307).

Compatibility

The BN-Series have a matching DIN case style that is complementary to the Lynx, Leopard and Tiger family of meters. BN-Meters are the OEM's choice for economical switchboard and process indication. For economy, each model is dedicated to a specific application and designed for quick and easy installation.

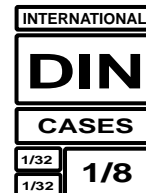

Specifications

- Input Configuration:** True differential
- Full Scale Ranges:** ±199.9mVDC ±1.999VDC (standard)
±19.99VDC ±199.9VDC
- Input Impedance:** Exceeds 100MΩ on 200mV, 2V ranges.
1MΩ other ranges.
- Input Protection:** ±100V AC/DC for 200mV, 2V and 20V ranges.
±250VAC/DC for 200V range
- Conversion Rate:** 3 readings per second
- Common Mode Rejection:** ... 80dB at DC
- Normal Mode Rejection:** 60dB at 50/60Hz for 200mV and 2V ranges.
- Common Mode Voltage:** ... -1V to +2VDC
- Accuracy:** ± (0.05% of reading + 1 digit)
- Temperature Coefficient:** 5ppm/°C in ratiometric mode 50ppm/°C in 200mV / 2V ranges
- Maximum resolution:** 100μV in 200mV range.
- Zero Stability:** Autozeroed. 0.1 counts per °C
- Display:** 0.56" high red LEDs. Display Hold, Blank and Test provided.
- Overrange Indication:** The most significant digit "1" is displayed with all the other digits blanked.
- Power Supply:** 5VDC @ 200mA.
- Operating Temperature:** 0°C to 60°C
- Storage Temperature:** -40°C to 85°C
- Relative humidity:** 95% (non condensing)
- Case Dimensions:** Bezel: 96X24 mm (3.62" X 0.95")
Depth behind bezel: 56.5 mm (2.23")
Plus 27 mm (1.06") for Push-On connector
or plus 17.5 mm (0.68") for Edge connector
- Weight:** 85 gms (3 oz)
125 gms (4.4 oz) when packed

BN-Series, For Those Applications Where Space Is A Premium

- BN-350.2/2/20/200V DC ranges, 3.5 digit, 5V DC Powered
- BN-35BCD Parallel or Multiplex BCD, 3.5 digit, 5V DC Powered
- BN-35CL4 to 20mA, Isolated 24V DC, 3.5 digit
- BN-35I0.2/2/20/200V DC ranges, Isolated 24V DC, 3.5 digit

- BN-40BCD Parallel or Multiplex BCD, 4.0 digit, 5V DC Powered
- BN-452/20/200V DC ranges, 4.5 digit, 5V DC Powered
- BN-45I2/20/200V DC ranges, Isolated 24V DC, 3.5 digit

Functional Diagram

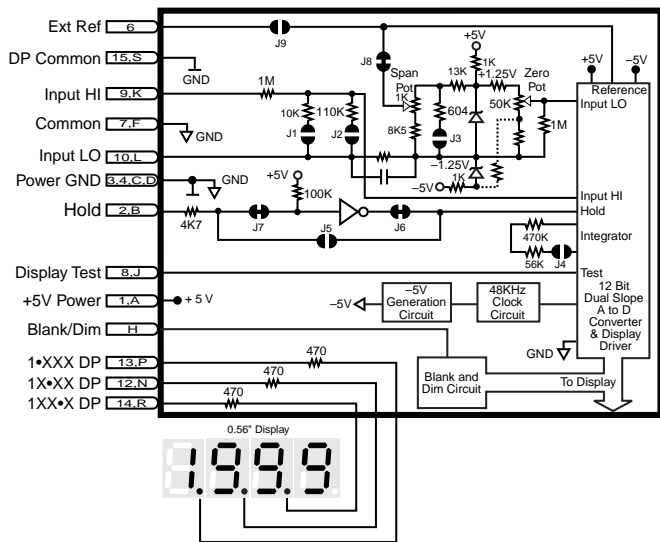

Connector Pinouts

The model BN-35 interconnects by means of a standard PC board edge connector having two rows of 15 pins, spaced on 0.156" centers. Texmate also offers a Push-On screw terminal connector that provides a great advantage in ease-of-use (see pg. four). Connectors are available from Texmate.

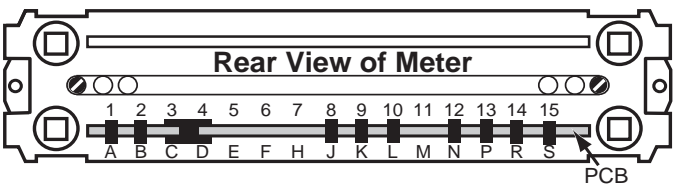

METER REAR WITH PCB EDGE CONNECTOR MOUNTED
(For mounting of screw terminal blocks see rear page)

COMPONENT SIDE PINS	SOLDER SIDE PINS
Positive DC Power Input - 1	A - Positive DC Power Input
Hold Reading - 2	B - Hold Reading
Negative DC Power Input - 3	C - Negative DC Power Input
Negative DC Power Input - 4	D - Negative DC Power Input
5	E
6	F
7	H
Display Test - 8	J - Display Test
Signal High Input - 9	K - Signal High Input
Signal Low Input - 10	L - Signal Low Input
11	M
Decimal Points - 12	N - Decimal Points
Decimal Points - 13	P - Decimal Points
Decimal Points - 14	R - Decimal Points
Decimal Select Common - 15	S - Hold/Test Common

SOLDER JUNCTION

Pins 1 & A - Positive DC Power Input: These pins are internally connected together. The positive end of the DC power is connected to these pins. The standard BN-35 meter is designed to be powered from a 5VDC power supply. Other power supplies options are available. See page three. Before using the meter, make sure that the appropriate power is being applied.

Pins 2 & B - Hold Reading: These pins are internally connected together. If these pins are left unconnected, the meter will operate in a free-running mode. When these pins are connected to the Hold/Test/Blank Common Pin 7, the meter will latch up. A/D conversions will continue, but the display will not be updated until Pins 2 & B are disconnected from Pin 7.

Pins 3, 4, C, and D - Negative DC Power Input: These pins are internally connected together. The negative end of the DC

power is connected to these pins. The standard BN-35 is designed to be powered from a 5VDC supply. Other power supply options are also available. See page three.

Pin 6 - External Reference Input: See page three for operating the meter with an external reference as a ratiometric voltmeter.

Pin 7 - Hold/Test/Blank Common Pin: The Display Hold/Test/Blank pins have to be connected to this pin to be activated.

Pin H - Display Blank/Dim: If this pin is connected to Pin 7, the display will be blanked out. If a 5KΩ potentiometer is connected between this pin and Pin 7, the brightness of the display may be smoothly adjusted.

Pins 8 and J - Display Test: These pins are internally connected together. All numeric display segments will light up when these pins are connected to the Hold/Test Blank Common Pin 7.

Pins 9 and K - Signal High Input: These pins are internally connected together. Signal high input for the meter. The input voltage can range from 200mV to 200VDC. By closing some solder jumpers, the user can change from one range to another. See page three for range change information.

Pins 10 and L - Signal Low Input: These pins are internally connected together. Signal low input of the A/D Converter.

Pins 11 and M - Reserved Pins: These pins have been reserved for future new functions. Please do not use them as tie points for external wiring, as they are connected to internal circuit points.

Pins 12 & N, 13 & P and 14 & R - Decimal Points: These are the decimal point pins. Connecting any of these pins to the Decimal Select Common Pin makes that particular decimal point come on.

Pins 15 and S - Decimal Select Common: These pins are internally connected together. The decimal point pins must be connected to this pin to come on.

Component Layout

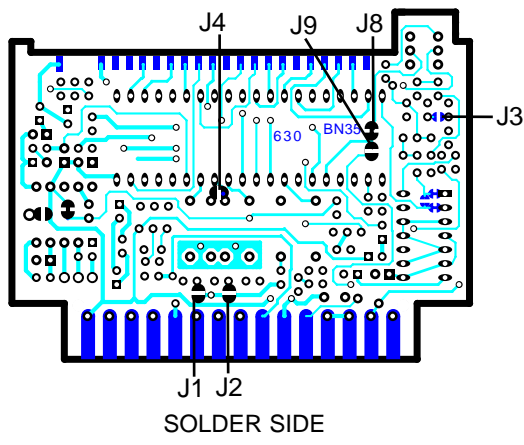
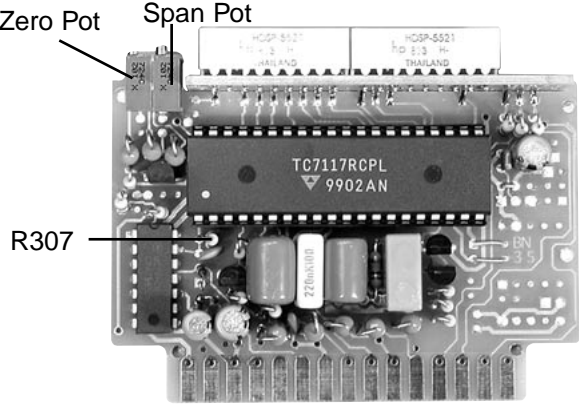

Signal Conditioning Components

SPAN SPAN Potentiometer (Pot)

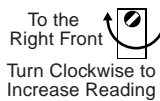

The 15 turn SPAN pot is always on the right side (as viewed from the front of the meter). Typical adjustment is 20% of the input signal range.

ZERO ZERO Potentiometer (Pot)

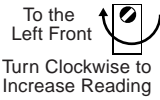

The Optional ZERO pot when installed is always to the right of the SPAN pot (as viewed from the front of the meter). Typically it enables the displayed reading to be offset ± 1000 counts.

Input Range Selection

Changing the range to **200mV, 20V or 200V**. The BN-35 comes standard as a 2VDC meter. The factory can recalibrate the meter to a different range either when the meter is ordered or as an after sale service using part number VRC-DPM.

For the user to change the range, closing of some jumpers by soldering and opening other jumpers is required. Follow the chart below to achieve the required range. See the above component layout to find location of jumpers. Remember to recalibrate the meter after every range change.

Input Range	Open Jumper	Closed Jumper
200mV	J1 and J2	J3 and J4
2V	J1, J2, J3 and J4	—
20V	J1, J3, J4	J2
200V	J2, J3, J4	J1

Calibration Procedure

The BN-35 is calibrated at the factory with a precision DC voltage source. Whenever the range is changed, the meter needs to be recalibrated. The Span Potentiometer is accessible with the front cover of the meter removed for user calibration.

1. Make sure there is proper DC power and input.
2. Connect the power supply.
3. Apply a positive signal input equal to 95% of the full scale input.
4. Adjust Span Potentiometer in the front of the meter so that the displayed reading agrees with the signal input.
5. The BN-35 is now calibrated and ready for use.

Opening Back Panel

Unscrew the knurled collars, and remove the mounting clips. Snap out the rear plastic plate. The BN-35 printed circuit board can then be easily removed by sliding it out from the rear of the case .

Front Bezel Descriptors

AC	Ω	kV	kVAR	m ³ /hr	Hz	RPM
V	mV	min	PF	°F	°C	Cos θ
DC	x10kN	μ A	PSIG	mS	kg/cm ²	psi
kW	W	kWH	pH	%	K	kPa
A	mbar	mA	MW	kA	RPS	MWH
mWs	μ m	kW/s	I	l/sec	ml	cm
ORP	mm/s	l/min	m/m	kg/sec	lbs	kg/hr
FT	bars	min ¹	m/min	Mvars	μ V	dB

To customize the front bezel, each BN-meter is supplied with a white printed clear adhesive label containing various popular descriptors. Choose the descriptor desired, peel off the adhesive backing and align the descriptor in the center right of the faceplate.

Power Supply

The BN-35 ships from the factory with a non-isolated 5VDC power supply. For applications where isolation is required between the power and signal grounds, use the Texmate model BN-35I. This model is available with 9V, 12V, 15V, and 24V power options and generates an internally isolated supply.

Push-On Screw Terminals

They provide the greatest convenience and ease of use. Texmate's exclusive optional Push-On Connectors combine an edge card connector and a 10 position screw terminal block. Push-On Connectors are ordered preconfigured for each specific power supply voltage and each optional power supply available for the BN-Series.



Part Number: CN-PUSH/BN

Optional PCB Edge Connector

PCB Edge Connector

A standard 30-pin edge connector (two rows of 15 pins on 0.156" centers) may be used to connect the BN-35 meter. Order part no. CN-L15.

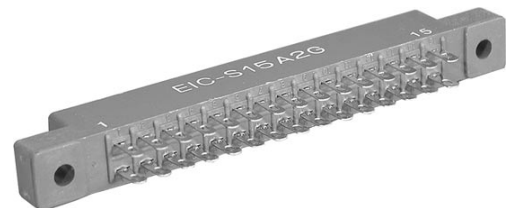

Custom Face Plates



Texmate Produces Thousands of Custom OEM Face Plates

Have Texmate Design and Build a Custom Face Plate to Suit your Next project!

- Custom face plates have a non-recurring artwork charge. A serial number is then assigned to each artwork, to facilitate re-ordering.
- Small Run or One-Off custom face plates incur an installation charge, and are generally printed on a special plastic film, which is then laminated to custom faceplate blanks as required.
- Large Run (250 pieces min): custom face plates are production silk screened, issued a part number, and held in stock for free installation as required by customer orders.
- OEMs may also order Custom Meter Labels, Box Labels Custom Data Sheets and Instruction Manuals.

BN Case Dimensions and Panel Cutouts

PANEL CUTOUT

Case will mount in standard 1/16 DIN cutouts

Panel adaptor plates are available to retrofit most existing panel cutouts.

For additional strength, extra Mounting Slide Clips can be ordered and doubled up one behind the other.
P/N:(75-DMT96X24)

When extra panel mounting tightness is required, optional Screw Mounting Clips are included which fit on the Mounting Slide Clips.

FRONT VIEW

1/16 DIN (96x24mm)

24 mm (0.95")

3 mm (0.12") typical

96 mm (3.78")

SIDE VIEW

5.4mm (0.21")

21.85 mm (0.86")

56.5mm (2.23")

27mm (1.06")

5mm (0.20")

Push-On Connector P/N:(CN/PUSH/BN)

TO REMOVE REAR COVER

Top Catches

Bottom Catch

Release Bottom Catch with a small flat blade, and lever upwards.

TOP VIEW

25.4mm (3.78")

Max. panel thickness

92.8 mm (3.6")

97.8mm (3.86")

91mm (3.59")

96mm (3.78")

Widest mountable panel cutout without using adaptors.

Various bezel colors are available. Black is standard.

The 96x24mm case is particularly suitable for mounting in mosaic panels or insulative panels. They can also stack mount, 2 up in existing cut-outs for 1/8 DIN (96x48mm) or 4 up in 1/4 DIN (96x96mm).

Ordering Information

Standard Options for this Model Number

Part Number	Description	List
► BASIC MODEL NUMBER Includes standard display and standard power supply unless optional versions are ordered.		
BN-35	0.2/2/20/200V DC ranges, 3.5 digit, 5V DC Powered	\$99
► DISPLAY		
STANDARD	Red LEDs, 0.56 inch high	N/C
BN-GREEN	Green LED, 0.56 inch high	\$10
BN-BRIGHT	Super bright Red LEDs, 0.56 inch high	\$15

Special Options and Accessories

Part Number	Description	List
► SPECIAL OPTIONS (Specify Inputs & Req. Reading)		
HD-CHANGE	Range change from the standard input as shown in BOLD type	\$7
VO-50K	Zero offset potentiometer 50k	\$5
VRC-DPM	Range change for BN-35/BN-35I listed ranges	\$10
CB-FS35	Non-Std Range and Scale Changes, 3.5 Digit Meters	\$10
► ACCESSORIES		
CN-L15	PCB Edge Connector, Solder Type, Dual Row 15 Pins	\$3.75
CN-PUSH/BN	BN Series Push-on Screw Terminal Block Connector	\$18
75-DMTC96X24	Side Slide Brackets, extra set (96x24mm only)	\$2
75-DBBZ96X24	Black Bezel for 96x24mm Case, BN and AM series	\$2
DN.CAS96X24	Din Case 96 X 24 Short Depth with Bezel	\$15

Prices subject to change without notice.

WARRANTY

Texmate warrants that its products are free from defects in material and workmanship under normal use and service for a period of one year from date of shipment. Texmate's obligations under this warranty are limited to replacement or repair, at its option, at its factory, of any of the products which shall, within the applicable period after shipment, be returned to Texmate's facility, transportation charges pre-paid, and which are, after examination, disclosed to the satisfaction of Texmate to be thus defective. The warranty shall not apply to any equipment which shall have been repaired or altered, except by Texmate, or which shall have been subjected to misuse, negligence, or accident. In no case shall Texmate's liability exceed the original purchase price. The aforementioned provisions do not extend the original warranty period of any product which has been either repaired or replaced by Texmate.

USER'S RESPONSIBILITY

We are pleased to offer suggestions on the use of our various products either by way of printed matter or through direct contact with our sales/application engineering staff. However, since we have no control over the use of our products once they are shipped, NO WARRANTY WHETHER OF MERCHANTABILITY, FITNESS FOR PURPOSE, OR OTHERWISE is made beyond the repair, replacement, or refund of purchase price at the sole discretion of Texmate. Users shall determine the suitability of the product for the intended application before using, and the users assume all risk and liability whatsoever in connection therewith, regardless of any of our suggestions or statements as to application or construction. In no event shall Texmate's liability, in law or otherwise, be in excess of the purchase price of the product.

Texmate cannot assume responsibility for any circuitry described. No circuit patent or software licenses are implied. Texmate reserves the right to change circuitry, operating software, specifications, and prices without notice at any time.

TEXMATE INC

995 Park Center Drive • Vista, CA 92081-8397

Tel: 1-760-598-9899 • USA 1-800-839-6283 • That's 1-800-TEXMATE

Fax: 1-760-598-9828 • Email: sales@texmate.com • Web: www.texmate.com

Texmate has facilities in Japan, New Zealand, Taiwan, and Thailand. We also have authorized distributors throughout the USA and in 28 other countries.

For product details visit www.texmate.com

Local Distributor Address