



Integra 1630 Low Profile Digital Metering System

MetersUSA
Meters@MetersUSA
www.Metersusa.com

a vital part of your world

DIN Integra 1630 Series

Multifunction Integra 1630 digital metering systems provide high accuracy 0.2% measurement, display and communication of all major electrical and power quality parameters including total harmonic distortion (THD) measurement up to the 31st harmonic. To suit user requirements, the range includes single-phase, 3-phase 3-wire and 3-phase 4-wire capability, all selectable at the point of installation.

This DIN 96 panel mounted enclosure offers simple programming and display of up to 35 electrical measurement parameters via a simple menu-driven user interface on the front panel. Integra 1630 digital metering system benefits from optional pulsed and digital communication outputs. This allows enhanced status information of up to 60 measured parameters to be communicated to SCADA, building management or other systems. Additionally, a simple Windows-based software package is available to remotely configure the Integra and display all 60 major electrical and power quality parameters.



Operation

The multifunction Integra 1630 digital metering system offers uncomplicated operation and high accuracy measurement of three-phase voltage, current, frequency, Watts, VAR, VA, energy, power factor, and total harmonic distortion measurement of both phase and system, current and voltage.

3-phase 4-wire system line-to-line voltage measurements are often a vector calculation of the line-to-neutral voltage measurements. However, Integra 1630 digital metering system includes true measurement of both line-to-neutral, and line-to-line measurements, ensuring accurate readings even with unusual wiring configurations (e.g. 4-wire open delta). To suit the requirements of individual power monitoring applications, the Integra 1630 digital metering system offers simple programming and display via the menu driven interface. Alternatively, an optional Windows-based software package can be used for remote configuration and monitoring. Once configured by either method, simultaneous monitoring of up to 60 electrical and power quality variables can be communicated to building management systems via pulsed or digital communication options.

If customer requirements extend beyond the original specified capabilities, the functionality of this innovative product is easily enhanced to meet new client expectations. Integra plug-in option modules allow cost effective upgrades with any combination of pulsed and digital communication outputs. The option module is interchangeable without recalibration.

Accuracy

Integra 1630 digital metering systems utilise true rms measurement techniques up to the 31st harmonic. An exceptional tolerance to high harmonic frequencies is achieved from a robust frequency detection method, which is able to detect the fundamental frequency on any phase. For safe maintenance, the system indicates CT current in the absence of voltage signals.

System Input

Designed for all low, medium and high voltage switchgear and distribution systems, the Integra 1560 and 1580 digital metering system offer programmable VT and CT ratio capability. Direct connection up to 480V AC with 5A CT inputs is standard, and 1A CT inputs are optional.

Features

- Low profile
- High contrast LED display
- LED annunciators for each measured parameter
- User programmable system configuration (4-wire default)
- Fully programmable VT and CT ratios
- Current demand per phase
- Elapsed time counter for connected loads
- Removable bezel for very low profile applications

Benefits

- True rms measurement
- High accuracy <0.2% on some measurements
- Configurable via software package or menu-driven interface
- Import and export monitoring

Applications

- Switchgear distribution systems
- Control panels
- Embedded generation
- Energy management
- Building management
- Utility power monitoring
- Process control
- Motor monitoring

Compliant

IEC1010-1 (BSEN 61010-1 – 2001)

MetersUSA
Meters@Metersusa.com
www.MetersUSA.com



Measurement and Display

Up to 35 electrical and power quality parameters can be configured and displayed.

- 1 System (average) volts
System (average) current
System (total) kW
- 2 System volts (average) THD%
System current (average) THD%
- 3 Volts L1 – N
Volts L2 – N
Volts L3 – N
(4 wire only)
Volts L1 – L2
Volts L2 – L3
Volts L3 – L1
(3 wire only)
- 4 Volts L1 – N THD%
Volts L2 – N THD%
Volts L3 – N THD%
(4 wire only)
Volts L1 – L2 THD%
Volts L2 – L3 THD%
Volts L3 – L1 THD%
(3 wire only)
- 5 Volts L1 – L2
Volts L2 – L3
Volts L3 – L1
(4 wire only)
- 6 Current L1
Current L2
Current L3
- 7 Current line 1 THD %
Current line 2 THD %
Current line 3 THD %
- 8 Neutral current
(4 wire only)
Frequency
Power factor (overall)
- 9 kVAr kVA kW
- 10 kW Hr import (7-digit resolution)
- 11 kVArh import (7-digit resolution)
- 12 kW Hr export (7-digit resolution)
- 13 kVArh export (7-digit resolution)
- 14 kW demand
Current demand
- 15 Maximum kW demand Maximum
current demand
- 16 Hours run

System Outputs

Pulsed outputs

Integra 1630 digital metering system offers optional single or dual pulsed outputs. Each output can be user programmed to represent import or export kWh, import or export kVArh or kVAh. The output pulses can be customised by both user programmable pulse rate divisor and pulse width. The solid state output relays have fully isolated volt-free connections via screw-clamp terminals.

Digital Communications

RS485 Modbus RTU

Integra 1630 digital metering systems offer an RS485 communication port for direct connection to SCADA systems using the Modbus RTU protocol or the Johnson Controls Metasys NII protocol. Remote monitoring enables the user to record systems parameters in real time, using high resolution numbers. The Integra establishes the format for the master's query automatically, and responds with the correct protocol using IEEE floating point values. The Modbus option also offers user programmable word order and support for function 8 subfunction 0, return query data diagnostic.

Enhanced status information of up to 60 measured parameters can be communicated to building management systems via the optional digital communications output. Any of 5 energy parameters can be output as pulses via optional pulse relay outputs.

Programmable Display

A two-button interface on the front panel of Integra 1630 units provides simple programming of system configuration (3-phase 4-wire etc), VT and CT ratio settings, configuration of selected communication options, and adjustment of operating parameters. To prevent unauthorised access to the product configuration settings, all set-up screens offer password protection. Once configured, status information can be viewed by scrolling through 16 screens featuring a high contrast 3-line, 4-digit LED display, with separate annunciators for each of the 35 measured parameters. Optional pulsed or digital outputs allow enhanced status information of up to 60 measured parameters to be communicated to building management systems.

MetersUSA

Meters@Metersusa.com

www.MetersUSA.com



Programmable Parameters

Parameter	Range
Password:	4 digit 0000 - 9999
CT primary current:	Maximum 9999A ** CT Secondary Current: 5A (1A option)
VT primary voltage:	Maximum 400kV **
VT secondary voltage:	Nominal input voltage ** maximum VT or CT ratios are limited so that the combination of primary voltage and current do not exceed 360MW at 120% of relevant input
Demand integration time:	8, 15, 20, 30, 60 minutes
3 independent resets:	Demands and maximum demands Energy registers Hours run
Pulse output duration:	60, 100, 200 milliseconds
Pulse rate divisors:	1, 10, 100, 1000
RS485 baud rate:	4.8, 9.6, 19.2, 38.4 kBd
RS485 parity and stop bits:	Odd or even with 1 stop bit or no parity with 1 or 2 stop bits

Specifications

Input	Value
Nominal input voltage:	57.7 to 277V LN, 100 to 480V LL
Max. continuous input voltage:	120% nominal
Max. short duration input voltage:	2 x nominal for 1 second, repeated 10 times at 10 second intervals
System VT ratios (primary):	Any significant 4-digit integer value up to 400kV **
Nominal input voltage burden:	< 0.2 VA
Nominal input current:	5A (1A option)
System CT primary values:	Any integer value up to 9999A **
Max. continuous input current:	120% nominal
Max. short duration input current:	20 x nominal for 1 second, repeated 5 times at 5 minute intervals
Nominal input current burden:	< 0.6 VA
	** maximum CT and VT ratios are limited so that the combination of primary voltage and current do not exceed 360MW at 120% of relevant input

Outputs (optional)	
RS485 communications:	Two wire half duplex
Baud rates:	4800, 9600, 19200, 38400
Pulsed:	Solid state relays
Pulse duration:	60, 100 or 200 milliseconds
Contact rating:	50mA max at 250V AC max.
Pulsed outputs:	1 or 2

Auxiliary	
Standard nominal supply voltage:	100V – 250V AC or DC (85V – 287V AC absolute limits) (85V – 312V DC absolute limits)
AC supply frequency range:	45–66Hz
AC supply burden:	6VA
Optional auxiliary DC supply:	12V–48V DC (10.2V–60V DC absolute limits)
DC supply burden:	6VA

Accuracy Defined

*Error in energy readings is expressed as a percentage of the energy count that would result from applying range maximum voltage and nominal current for the same measurement period.

Error change due to variation of an influence quantity (except temperature) by varying one influence quantity within range of use, whilst keeping all other influence quantities at their nominal value is less than twice the error allowed for the reference condition applied in the test.

(This definition is applied to limit the number of combinations to be applied during type tests)

Error due to temperature variation is as above.

Error in measurement when a measurand is within its measuring range, but outside its reference range is less than twice the error allowed at the end of the reference range adjacent to the section of the measuring range where the measurand is currently operating / being tested.

*Error in energy readings is expressed as a percentage of the energy count that would result from applying a range maximum voltage and nominal current for the same measurement period.

MetersUSA
Meters@Metersusa.com
www.MetersUSA.com



Measuring Ranges	
Voltage:	80-120% of nominal (functional 5-120%)
Current:	5-120% of nominal
Frequency:	45-66Hz
Power factor:	0.8 capacitive-1-0.8 inductive (functional 4 quadrant, 0-1 lag/lead)
THD:	Up to 31st harmonic 0-40% Measured voltage >5% of range Measured current >5% of nominal Full accuracy of voltage >25% of range Full accuracy of current >25% of nominal
Energy:	7 digit resolution

Reference conditions	
Ambient temperature:	23 ±1°C
Input frequency:	50 or 60Hz ±2%
Input waveform:	Sinusoidal (distortion factor < 0.005)
Auxiliary supply voltage:	Nominal ±1%
Auxiliary supply frequency:	Nominal ±1%
AC auxiliary supply waveform:	Sinusoidal (distortion factor < 0.05)
Magnetic field of external origin:	Terrestrial flux

Accuracy	
Voltage:	±0.17% of range maximum
Current:	±0.17% of nominal
Frequency:	0.15% of mid frequency
Active power:	±0.2% of range maximum
Power factor:	1% of unity
Reactive power (VAr):	±0.5% of range maximum
Apparent power (VA):	±0.2% of range maximum
THD:	±1%
Neutral current calculated:	±0.95% of nominal
Energy:	0.3% of range maximum (Better than class 1) IEC1036 Sect 4.6)
kVArh:	0.6% of range maximum
Temperature coefficient:	Voltage and current typical: 0.013%/°C Watts typical: 0.018%/°C

Enclosure	
Enclosure style:	DIN 96 panel mount
Compliant with:	IEC 1010-1/ BSEN 61010-1 : 2001 CAT III, CE EMC and LVD directives
Material:	Polycarbonate
Terminals:	Shrouded screw-clamp 0.05mm to 4mm wire
Dielectric voltage:	Withstand test 3.25kV rms 50Hz for 1 minute between all electrical circuits
Operating temperature:	-20 to +60°C
Storage temperature:	-30 to +80°C
Relative humidity:	0-90% (non condensing)
Warm-up time:	1 minute
Shock:	30g in 3 planes
Vibration:	10-18Hz, 1.5mm peak-to-peak 18-150Hz @1g
IP protection:	IP54
Dimensions:	96mm wide x 96mm high x 79mm deep (max). Typically <60mm depth behind panel 3.78" wide x 3.78" high x 3.11" deep (max)
Panel cut-out:	92mm x 92mm, 3.62" x 3.62"

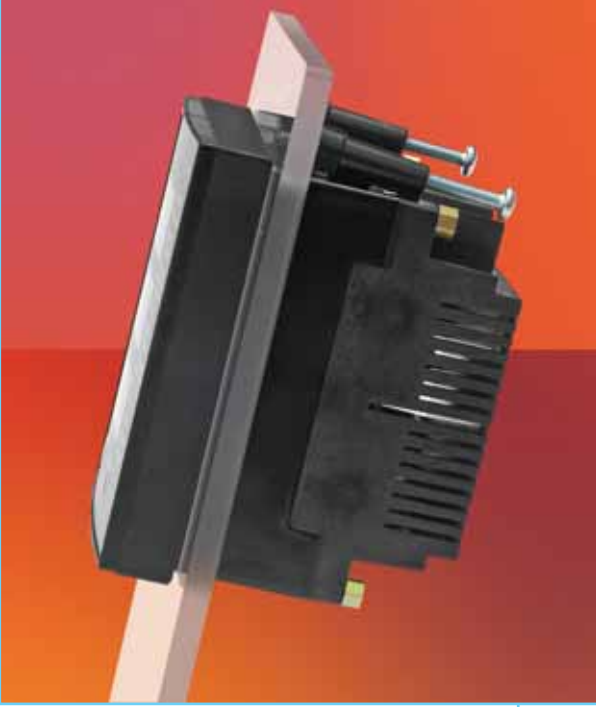

Product Codes

INT - XX XX - X - X - X - XXX

Product Family	System Type	Input V	Input I	Auxiliary V	Options
16	30-LED DIN96	L - 57.7 - 139 L - N (100 - 240 L - L)	5 - 5A 1 - 1A	L - 12 - 48 V DC M - 100 - 250V AC/DC	000 - No Option 010 - Modbus
Low Profile	User Selectable System Type	M - 140 - 277 L - N (241 - 480 L - L)			100 - One Pulse 110 - One Pulse One Modbus
Features as Specified	Factory Default - 4 Wire				200 - Two Pulse 210 - Two Pulse One Modbus

Pre-configured Spares/Options

The functionality of existing Integra 1630 digital metering system products can be easily upgraded with the use of Crompton preconfigured plug-in cards.

Option Code	Description
OPT-1630-M-010	Modbus communications card with 100-250V auxiliary
OPT-1630-M-100	Single pulsed output card with 100-250V auxiliary
OPT-1630-M-110	Single pulsed modbus card with 100-250V auxiliary
OPT-1630-M-200	Dual pulsed card with 100-250V auxiliary
OPT-1630-M-210	Dual pulsed modbus card with 100-250V auxiliary
OPT-1630-L010	Modbus communications card with 12-48V DC auxiliary
OPT-1630-L100	Single pulsed output card with 12-48V DC auxiliary
OPT-1630-L110	Single pulsed modbus card with 12-48VDC auxiliary
OPT-1630-L200	Dual pulsed card with 12-48VDC auxiliary
OPT-1630-L210	Dual pulsed modbus card with 12-48VDC auxiliary

Order Code Example

INT-1630-M-5-M-110
 Integra 1630 digital metering system, 3-phase 4-wire, nominal input voltage, 140-277V L-N (241-480V) L-L, 5A CT input, auxiliary supply 100 to 250V AC or DC, one relay pulsed output and one RS485 Modbus communication port.

MetersUSA
 Meters@Metersusa.com
 www.MetersUSA.com

Import and Export Connections

The connections diagrams opposite assume an import power configuration; therefore any power flow towards the load will register as imported energy. If power flows away from the load in an export power situation, then the power will register as exported energy.

Auxiliary Supply

The Integra 1630 digital metering system should ideally be powered from a dedicated supply: either 100-250 AC, DC (85–280V AC absolute or 85-315V DC absolute), or 12-48V DC (10.2V-60V DC absolute). However, the device may be powered from the signal source, provided the source remains within the working range of the chosen auxiliary supply.

Fusing

It is recommended that all voltage lines be fitted with 1 amp fuses.

Safety/Ground Connections

For safety reasons, all CT secondary connections should be grounded in accordance with local regulations.

Dimensions

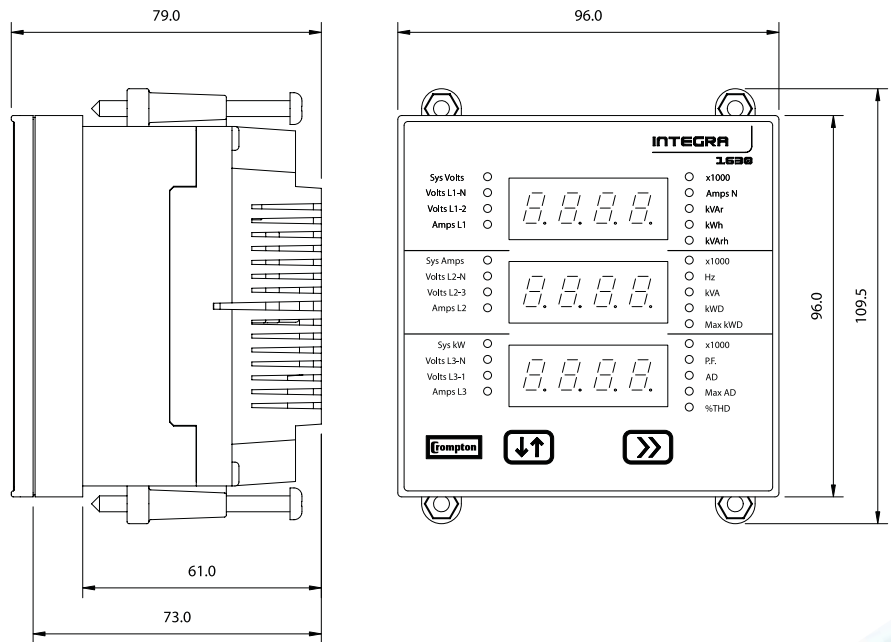

Wiring

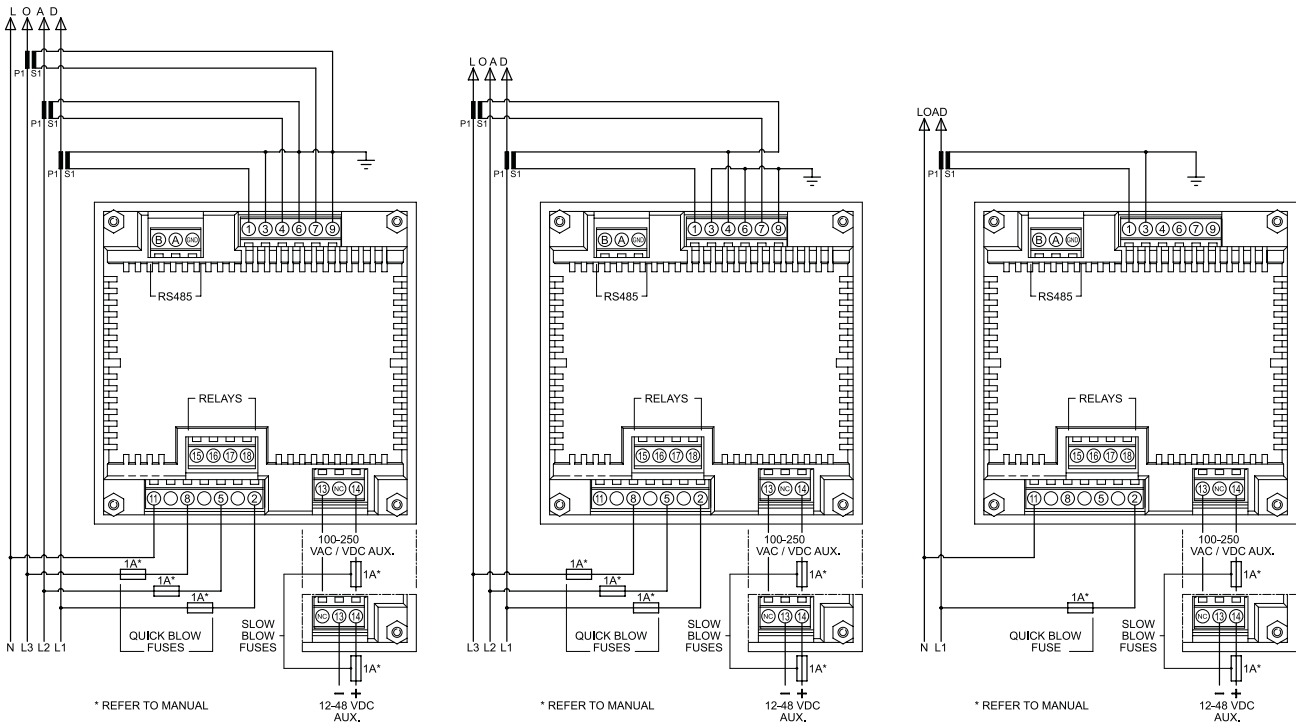

MetersUSA
Meters@Metersusa.com
www.MetersUSA.com





CT Accessories

Crompton Instruments also offer a complete range of high quality current transformers offering comprehensive measuring and protection class accuracies. The range offers a wide selection of system current ratings, busbar sizes, case widths, apertures and mounting options to every application.

Features

- Cost effective moulded case measuring current transformers
- Limited range include the seven most popular sizes of current transformers
- Ratio ratings from 30/5 to 4000/5
- Comprehensive measurement of class accuracy
- Wide range of system current ratings, busbar sizes, case widths and apertures
- Wire sealable terminal covers
- Feet mounting and busbar options

Product Codes

Product code	Ratio range	VA at CL 3	VA at CL 1	VA at CL 0.5
PE201	30/5	1.5	-	-
PE201	40/5	1.5	-	-
PE201	50/5	-	1.5	-
PE201	60/5	-	1.5	-
PE201	80/5	-	4	-
PE201	100/5	-	4	-
PE201	200/5	-	8	-
PE201	250/5	-	10	-
PE301	75/5	1	-	-
PE301	80/5	1	-	-
PE301	100/5	-	1	-
PE301	125/5	-	1	-
PE301	150/5	2.5	1	-
PE301	200/5	3	2.5	-
PE301	250/5	3	2.5	-
PE301	300/5	5	2.5	-
PE301	400/5	7.5	5	-
PE301	500/5	7.5	5	-
PE301	600/5	7.5	5	-
PE401	150/5	-	2.5	-
PE401	200/5	-	2.5	-
PE401	300/5	-	2.5	-
PE401	400/5	7.5	5	-
PE401	500/5	-	7.5	5
PE401	600/5	-	7.5	5
PE401	750/5	-	7.5	5
PE401	800/5	-	7.5	5

PE 201

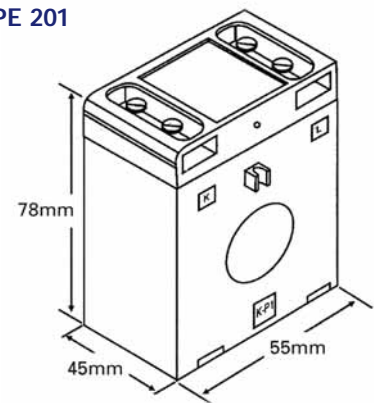

PE 301

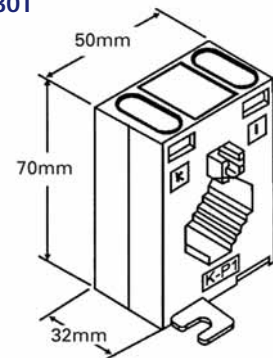

PE 401

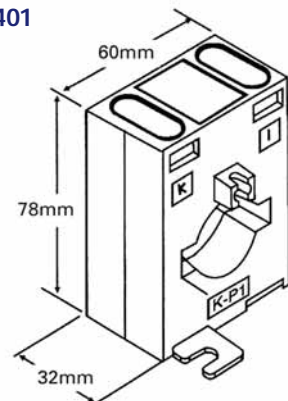



PE 601

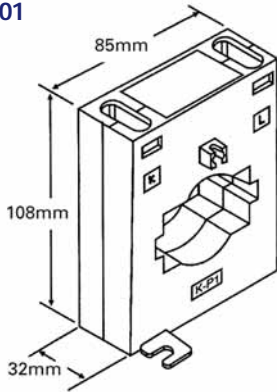

PE 801

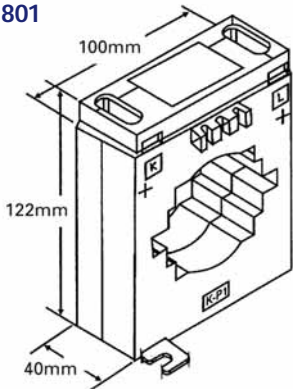

PE 1001

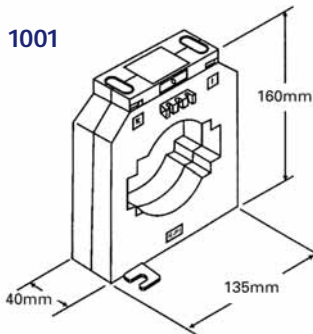

Product code	Ratio range	VA at CL 3	VA at CL 1	VA at CL 0.5
PE601	400/5	-	10	-
PE601	500/5	-	10	-
PE601	600/5	-	15	10
PE601	800/5	-	15	10
PE601	1000/5	-	15	10
PE601	1200/5	-	-	15
PE601	1500/5	-	-	15
PE601	1600/5	-	-	15
PE801	400/5	-	5	5
PE801	500/5	-	7.5	5
PE801	600/5	-	7.5	5
PE801	800/5	-	15	10
PE801	1000/5	-	15	10
PE801	1200/5	-	-	10
PE801	1500/5	-	15	10
PE801	1600/5	-	15	10
PE801	2000/5	-	15	10
PE1001	400/5	-	-	5
PE1001	500/5	-	10	5
PE1001	600/5	15	10	5
PE1001	800/5	-	15	10
PE1001	1000/5	-	15	15
PE1001	1200/5	-	15	15
PE1001	1500/5	-	30	15
PE1001	1600/5	-	30	15
PE1001	2000/5	-	30	15
PE1001	3000/5	-	-	30
PE1001	4000/5	-	-	30



tyco

Electronics

Tyco Electronics UK Limited, Crompton Instruments
Freebournes Road, Witham, Essex, CM8 3AH, UK
Phone: ++44 (0) 870 870 7500
Fax: ++44 (0) 870 240 5289

a vital part of your world

© Tyco Electronics CI-EPP-Integra1630-05/06

All of the above information, including drawings, illustrations and graphic design, reflects our present understanding and is to the best of our knowledge and belief correct and reliable. Users, however, should independently evaluate the suitability of each product for the desired application. Under no circumstances, does this constitute an assurance of any particular quality or performance. Such an assurance is only provided in the context of our product specifications or explicit contractual arrangements. Our liability for these products is set forth in our standard terms and conditions of sale. Tyco is a trademark. CROMPTON is a trademark of Crompton Parkinson Ltd. and is used by Tyco Electronics under licence. Other trademarks or company names used herein are the property of respective owners.

Energy Division –economical solutions for the electrical power industry: cable accessories, connectors & fittings, electrical equipment, instruments, lighting controls, insulators & insulation enhancement and surge arresters.